



MINI SKID LOADER

MODELS 930

PARTS MANUAL

RAMROD EQUIPMENT

(A Division of Leon's Mfg. Company Inc.)

Canada

P.O. Box 5002
135 York Road East
Yorkton, Saskatchewan
S3N 3Z4

Phone: (800) 667-1581

Fax: (306) 782-1884

email: sales@ramrodequip.com

web site: www.ramrodequip.com

USING THE PARTS LIST

ITEM

The item number is the identifying number from the illustration.

PART NUMBER

The part numbers that appear in the part number column are 7 digit numbers by which the components may be identified and ordered.

DESCRIPTION

This column contains the name and description of the part.

QUANTITY

This column shows the quantity of each mini-skid component used.

ORDERING PARTS

When ordering parts, be sure to state:

1. Part Number
2. Full Description
3. Quantity Required
4. Mini-Skid Model and Serial Number

NOTE: The references to right and left used throughout this manual refer to the position when operating the machine, facing forward.

RAMROD TASKMASTER 930 PARTS MANUAL INDEX

TITLE	PAGE
Parts List - Decals	1
Body Assembly.....	2
Parts List – Body Assembly.....	3
Lift & Leveling Arm Assembly.....	4
Parts List – Lift & Leveling Arm Assembly.....	5
Wheel Assembly.....	6
Parts List – Wheel Assembly.....	7
Track Assembly.....	8
Parts List – Track Assembly.....	9
Hydraulic Circuit Diagram.....	10
Hydraulic Parts Layout	12
Parts List – Hydraulic System	13
Hydraulic Cylinders	14
Parts List – Hydraulic Cylinders	15
23hp Kawasaki Engine (FH680V)	16
Parts List – 23hp Kawasaki Engine (FH680V)	17
Hydraulic Oil Cooler Assembly.....	18
Parts List – Hydraulic Oil Cooler Assembly	19

PARTS LIST - DECALS

P/N	Description	Qty.
1179163	DECAL HYDRAULIC FLUID	1
1179162	DECAL GASOLINE	2
1179150	DECAL OPERATING INSTRUCTIONS	1
1179149	DECAL SAFETY FIRST	1
1179159	DECAL OPERATING LEVERS	1
1179312	DECAL FLOW DIVIDER TORTOISE/HARD	1
1260184	DECAL 'R/R' -W/STRIPES	2
1178043	DECAL PLAIN RAMHEAD SMALL	1
1235783	DECAL 930	3
1235784	DECAL 'PRO-SERIES' -W/STARS	2
1178054	DECAL MADE IN NORTH AMERICA	1
1179152	DECAL MINI PATENTS	1
1178055	DECAL LIFT POINT	2
1178056	DECAL CYLINDER LOCK	1
1178057	DECAL AUXILLIARY POWER	1
1235786	DECAL 'RAMROD PRO-SERIES' -W/STRIPES	2

BODY ASSEMBLY

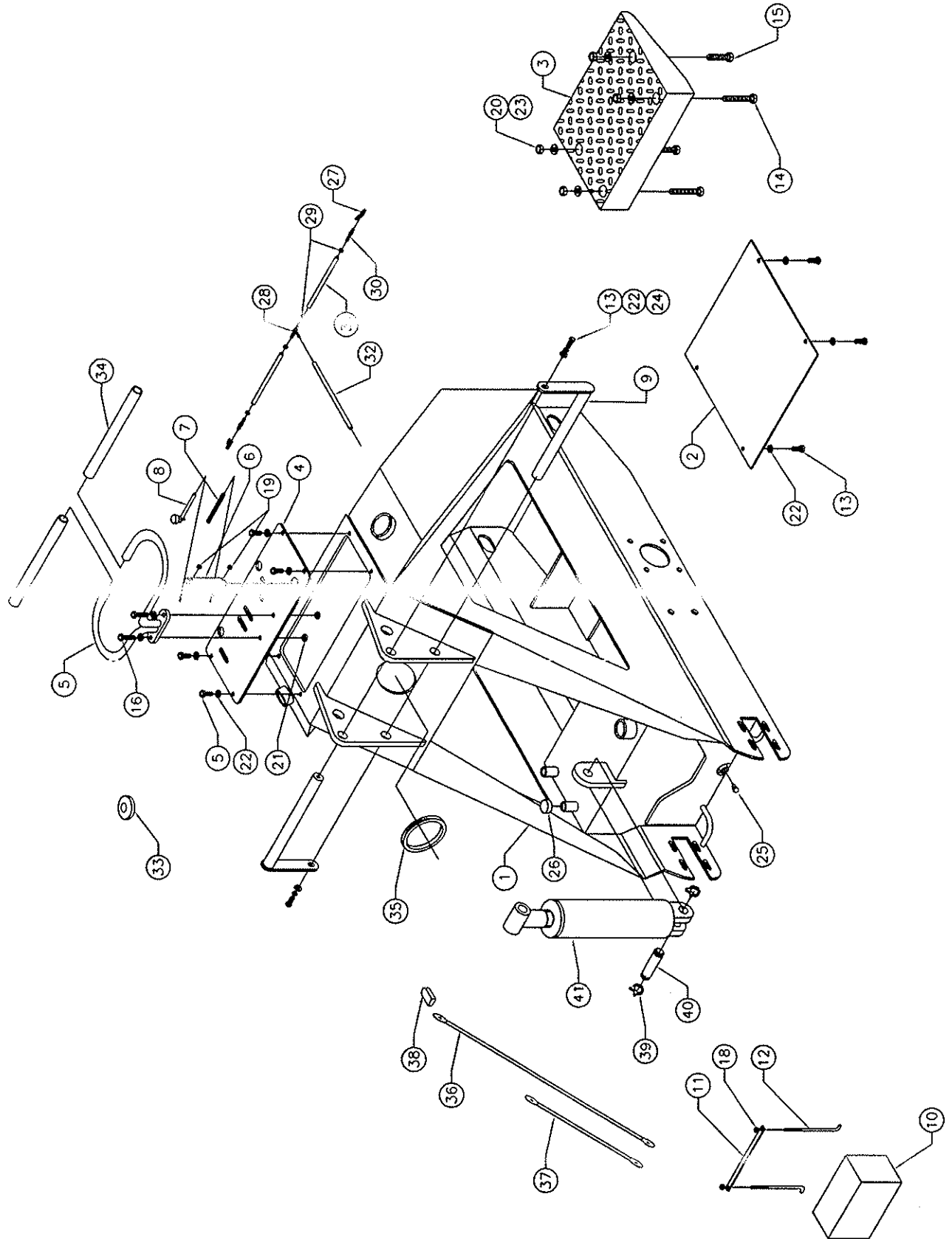

PARTS LIST - BODY ASSEMBLY

Item	P/N	Description	Qty.
1	1235001	905 SERIES BODY	1
2	1235043	BOTTOM COVER PLATE	1
3	1144241	COUNTERWEIGHT OPERATOR PLATFORM	1
4	1235048	TOP COVER	1
5	1235083	905 SERIES OPERATOR BAR	1
6	1235087	FLOW DIVIDER EXTENSION	1
7	1235088	FLOW DIVIDER THREADED ROD	1
8	1235505	FLOW DIVIDER HANDLE AND KNOB	1
9	1233149	PIN, 1 1/8" LIFT/LEVELLING ARM PIN	2
10	1179130	BATTERY	1
11	1233158	BATTERY CROSS BAR	1
12	1230533	BATTERY TIE DOWN BOLT	2
13	1102001	GR. 5 UNC HEX BOLT, 3/8" X 1" LONG	10
14	1102057	GR. 5 UNC HEX BOLT, 1/2" X 3 1/2" LONG	2
15	1102055	GR. 5 UNC HEX BOLT, 1/2" X 2 1/2" LONG	2
16	1102002	GR. 5 UNC HEX BOLT, 3/8" X 1 1/2" LONG	2
18	1102515	GR. 5 UNC HEX NUT, 1/4"	2
19	1102522	GR. 5 UNF HEX NUT, 5/16"	4
20	1102535	GR. 5 UNC HEX NUT, 1/2"	4
21	1102526	GR. 5 UNC HEX NYLOCK NUT, 3/8"	2
22	1102590	LOCKWASHER, 3/8"	10
23	1102592	LOCKWASHER, 1/2"	4
24	1102609	FLATWASHER, 3/8"	4
25	1122919	3/8" NPT PLUG	3
26	1124366	3/4" NPTF CAP	1
27	1124711	SHUT OFF VALVE	2
28	1124365	1/4" HOSE BARB TEE	1
29	1123184	1/4" GEAR CLAMP	6
30	1234712	ADAPTER, 1/4" NPTM X 1/4" HOSE BARB	2
31	1235506	1/4" FUEL LINE, 8" LONG	2
32	1235507	1/4" FUEL LINE, 20" LONG	1
33	1190064	FUEL/OIL FILLER CAP	3
34	1190086	HANDLEBAR TUBING	2
35	1235508	HOLE RUBBER, 13 3/4" LONG	1
36	1235504	POSITIVE BATTERY CABLE	1
37	1235503	NEGATIVE BATTERY CABLE	1
38	1234327	POSITIVE BATTERY TERMINAL COVER	1
39	1500115	PIN RETAINER	2
40	1233162	GROOVE PIN 1" X 4 15/16" LG	1
41	1127485	LIFT CYLINDER	1

LIFT AND LEVELING ARM ASSEMBLY

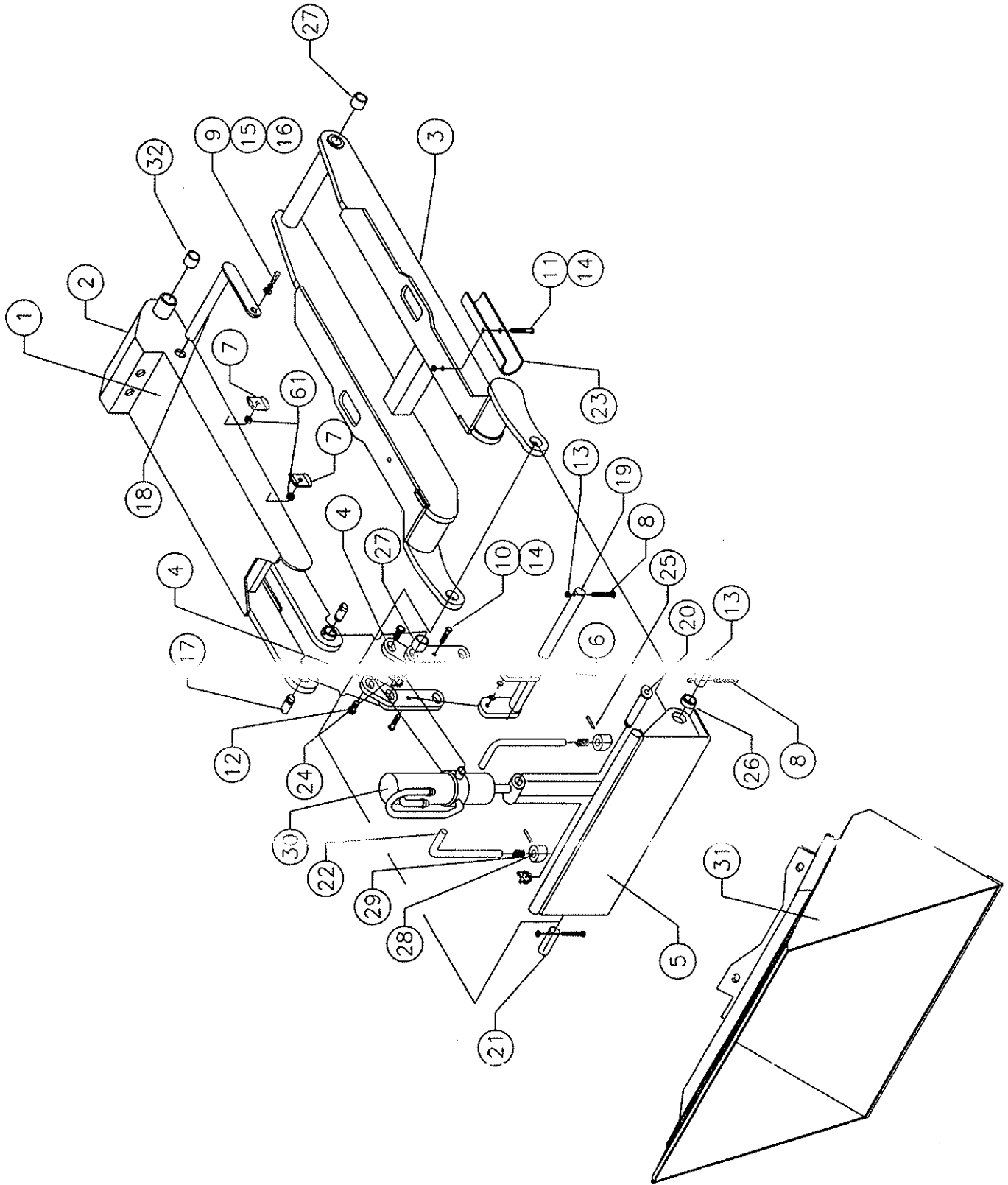

PARTS LIST - LIFT & LEVELING ARM ASSEMBLY

Item	P/N	Description	Qty.
1	1234425	LIFT FRAME WELDMENT	1
2	1190026	LIFT ARM RUBBER	1
3	1234409	LEVELING FRAME WELDMENT	1
4	1231111	LEFT SELF LEVELING LINK	1
4	1231112	RIGHT SELF LEVELING LINK	1
5	1231122	QUICK ATTACH BRACKET	1
6	1231123	CYLINDER SPACER	1
7	1707130	2 LINE CLAMP	2
8	1101954	GR. 5 UNC HEX BOLT, 5/16" X 2" LONG	3
9	1102001	GR. 5 UNC HEX BOLT, 3/8" X 1" LONG	2
10	1102002	GR. 5 UNC HEX BOLT, 3/8" X 1 1/2" LONG	2
11	1102006	GR. 5 UNC HEX BOLT, 3/8" X 3 1/2" LONG	1
12	1231171	CYLINDER RETAINING BOLT, MACHINED	2
13	1102521	GR. 5 UNC NYLOCK HEX NUT, 5/16"	3
14	1102536	GR. 5 UNC NYLOCK NUT, 3/8"	3
15	1102590	LOCKWASHER, 3/8"	2
16	1102609	FLATWASHER, 3/8"	2
17	1231073	PIN, 1" X 2 15/15"	2
18	1233148	PIN, 1 1/8" LIFT CYLINDER ARM PIN	1
19	1231075	PIN, DRILLED 1" X 9" LONG	1
20	1231044	PIN, GROOVE 1" X 3 1/2" LONG	1
21	1231047	PIN, DRILLED 1" X 2 11/16" LONG	2
22	1231118	QUICK ATTACH PIN	2
23	1234190	CYLINDER LOCK	1
24	1500115	PIN RETAINER	3
25	1102762	COTTER PIN	2
26	1115510	5/8" X 1" TENSION BUSHING	8
27	1115516	1" X 1" TENSION BUSHING	2
28	1231120	PIN PIVOT	2
29	1105620	SPRING	2
30	1127336	TILT CYLINDER	1
31	1232069	42" STANDARD BUCKET	1
32	1115513	1 1/8" X 1" TENSION BUSHING	2

WHEEL ASSEMBLY

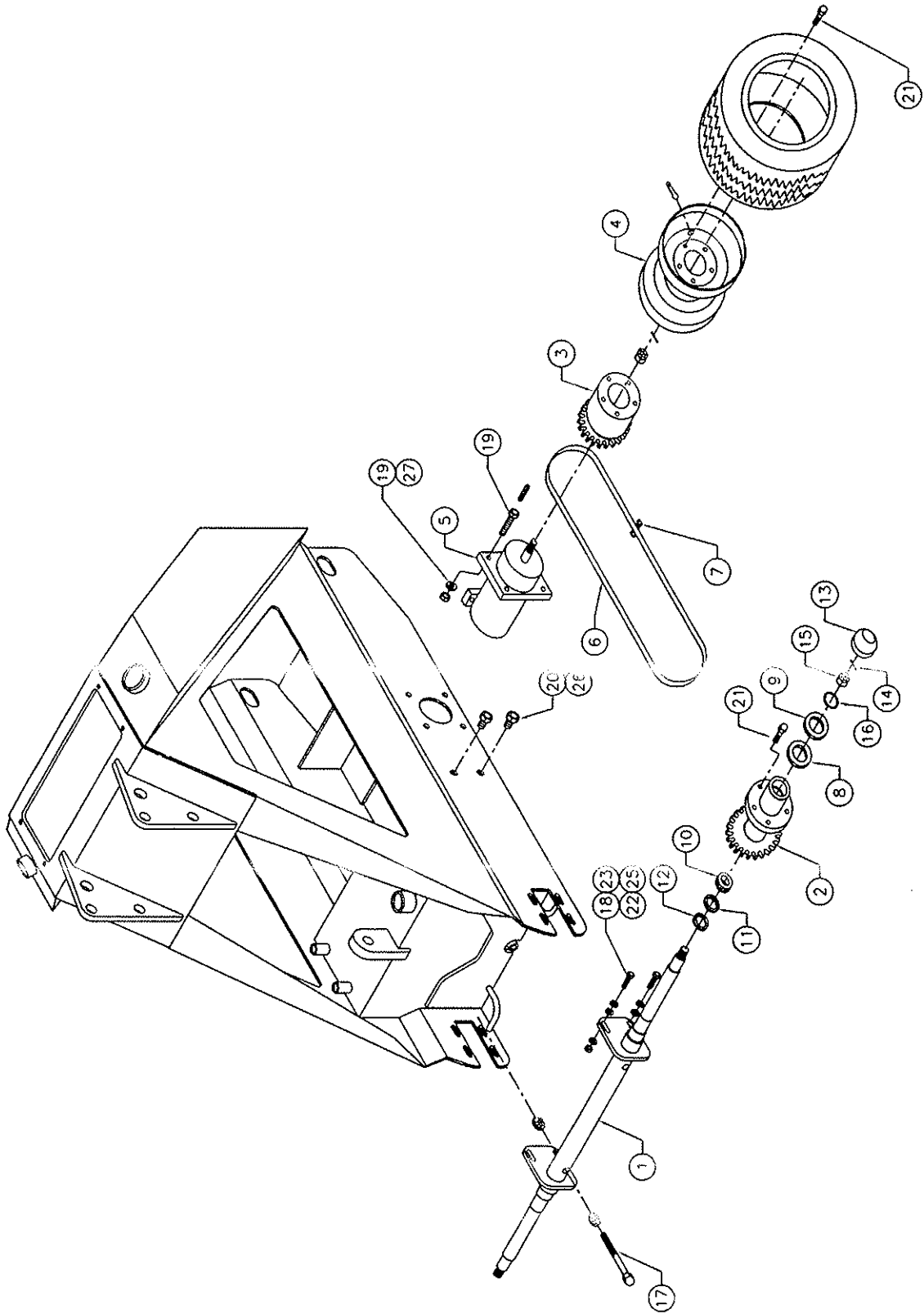

PARTS LIST - WHEEL ASSEMBLY

Item	P/N	Description	Qty.
1	1235040	FRONT AXLE WELDMENT	1
2	1230619	FRONT HUB/SPROCKET WELDMENT	2
3	1235080	REAR HUB/SPROCKET WELDMENT	2
4	1135092	TIRE ASSEMBLY, 4.00 X 8 - 4 PLY	4
4	1135082	TIRE ASSEMBLY, 18 X 6.5 - 8, 4 PLY	4
4	1135083	TIRE ASSEMBLY, 16 X 6.5 - 8, LEFT (CHEVRON)	2
4	1135161	TIRE ASSEMBLY, 16 X 6.5 - 8, RIGHT (CHEVRON)	2
4	1135086	TIRE ASSEMBLY, 18 X 9.5 - 8, (CHEVRON)	4
5	1127473	WHEEL MOTOR ASSEMBLY	2
6	1113372	WHEEL CHAIN, #60H - 93 PITCH	2
7	1113376	CONNECTOR LINK, #60H	2
8	1135343	CUP, BEARING RACE, OUTER	2
9	1135344	BEARING, ROLLER CONE, OUTER	2
10	1135251	CUP, BEARING RACE, INNER	2
11	1135250	BEARING, ROLLER CONE, INNER	2
12	1135252	GREASE SEAL	2
13	1135345	DUST CAP	2
14	1102768	COTTER PIN	2
15	1105400	CASTELLATED NUT	2
16	1102637	MACHINERY BUSHING	2
17	1231023	TENSIONER BOLT	2
18	1102002	GR. 5 UNC HEX BOLT, 3/8" X 1 1/2"	4
19	1102051	GR. 5 UNC HEX BOLT, 1/2" X 1 1/2"	8
20	1102097	GR. 5 UNC HEX BOLT, 5/8" X 1"	4
21	1102509	UNF HEX WHEEL BOLT, 1/2" X 1"	20
22	1102541	3/8" FLATWASHER, EXTRA HEAVY	8
23	1102590	3/8" LOCKWASHER	4
24	1102611	FLATWASHER, 1/2"	8
25	1102525	GR. 5 UNC HEX NUT, 3/8"	4
26	1102540	GR. 5 UNC HEX NUT, 5/8"	4
27	1102537	GR. 5 UNC NYLOCK HEX NUT, 1/2"	8
28	1102543	GR. 5 UNC NYLOCK NUT, 5/8"	4

TRACK ASSEMBLY

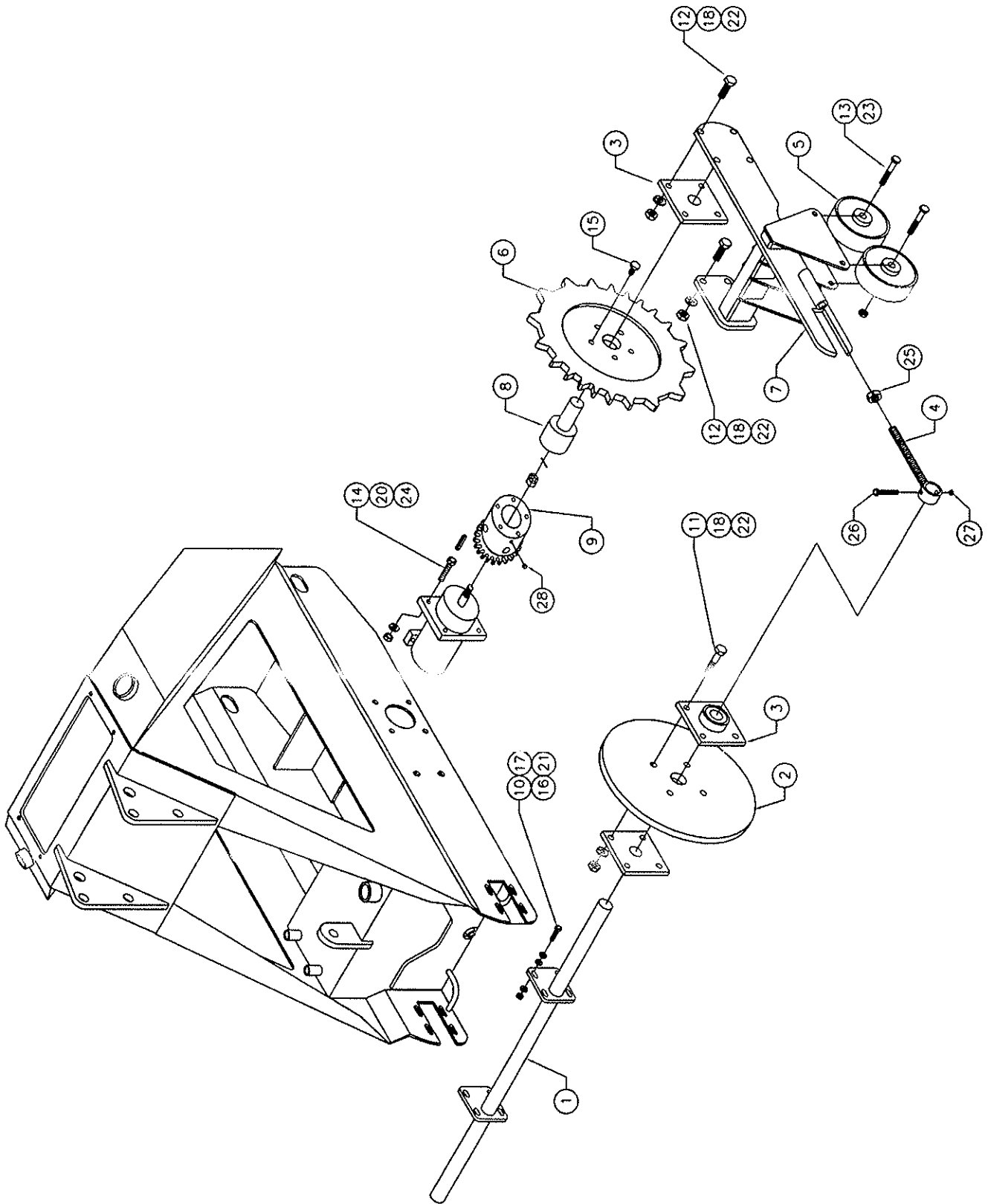

PARTS LIST - TRACK ASSEMBLY

Item	P/N	Description	Qty.
1	1235050	FRONT AXLE WELDMENT	1
2	1235061	FRONT IDLER	2
3	1117176	BEARING CASTING	6
4	1235055	TENSIONER	2
5	1232936	TRACK ROLLER	8
6	1232926	DRIVE SPROCKET	2
7	1235065	LEFT TRACK FRAME	1
7	1235066	RIGHT TRACK FRAME	1
8	1235060	TRACK STUB SHAFT	2
9	1235080	REAR HUB/SPROCKET WELDMENT	2
10	1102002	GR. 5 UNC HEX BOLT, 3/8" X 1 1/2"	8
11	1102104	GR. 5 UNC HEX BOLT, 5/8" X 3"	8
12	1102102	GR. 5 UNC HEX BOLT, 5/8" X 2"	12
13	1102057	GR. 5 UNC HEX BOLT, 1/2" X 3 1/2"	8
14	1102053	GR. 5 UNC HEX BOLT, 1/2" X 2"	8
15	1102509	1/2 UNF X 7/8 WHEEL BOLT, 60DEG. TAPER	10
16	1102641	3/8" FLATWASHER, EXTRA HEAVY	16
17	1102590	3/8" LOCKWASHER	8
18	1102594	5/8" LOCKWASHER	20
20	1102592	1/2" LOCKWASHER	8
21	1102525	GR. 5 UNC HEX NUT, 3/8"	8
22	1102540	GR. 5 UNC HEX NUT, 5/8"	20
23	1102537	GR. 5 UNC NYLOCK NUT, 1/2"	8
24	1102535	GR. 5 UNC HEX NUT, 1/2"	8
25	1102545	GR. 5 UNC HEX NUT, 3/4"	2
26	1101955	GR. 5 UNC HEX BOLT, 5/16" X 2.5"	2
27	1102521	GR. 5 UNC HEX NUT, 5/16"	2
28	1102703	1/2" UNC 1/2" SET SCREW, SOCKET HEAD, GR.5 PLATED	2

HYDRAULIC CIRCUIT DIAGRAM

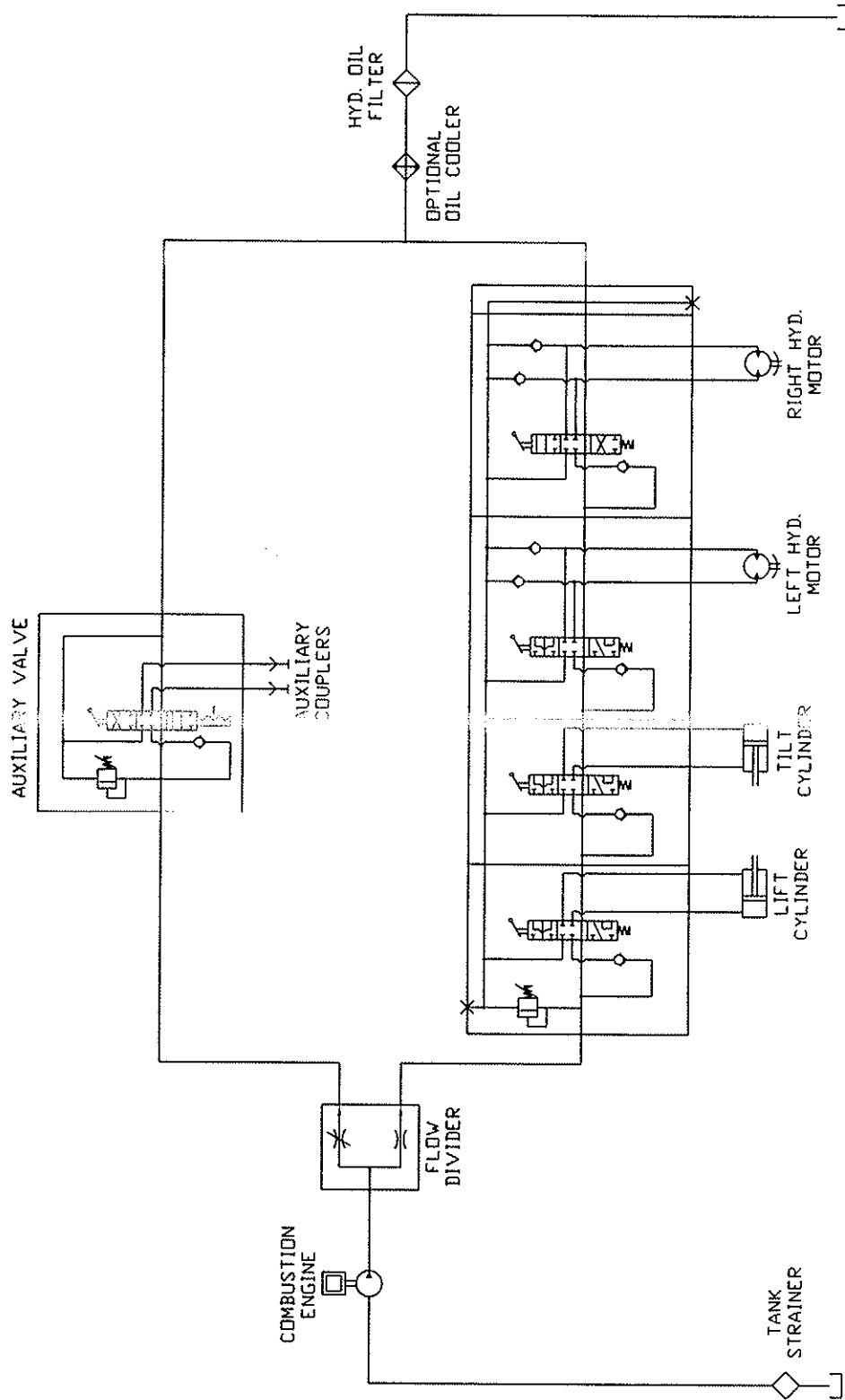

PARTS LIST - HYDRAULIC SYSTEM

Item	P/N	Description	Qty.
1	1127473	HYDRAULIC WHEEL MOTOR, 29 CU IN	2
2	1128365	MACHINE FUNCTION VALVE, 4 SPOOL SECTIONAL	1
3	1125841	AUXILLIARY FUNCTION VALVE, 1 SPOOL	1
4	1235500	FLOW DIVIDER	1
5	1179325	GEAR PUMP	1
6	1127485	LIFT CYLINDER	1
7	1127336	TILT CYLINDER	1
8	1123574	HYD. HOSE, 47" X 1/2", #10 ORBM SW 90 X #8 ORBM SW	4
9	1123606	HYD. HOSE, 30" X 1/2", #8 JICF SW X #8 ORBM SW	4
10	1123568	HYD. HOSE, 34.5" X 3/8", #8 JICF SW X #8 ORBM SW	1
11	1122757	HYD. HOSE, 70" X 3/8", #8 JICF SW X #8 ORBM	2
12	1123609	HYD. HOSE, 45" X 1/2", #8 JICF SW (2)	1
13	1123568	HYD. HOSE, 25" X 1/2", #8 ORBM X #8 ORBM SW	1
14	1190107	SUCTION/RETURN HOSE, 15" X 1"	1
15	1123606	HYD. HOSE, 30" X 1/2", #8 JICF SW X #8 ORBM SW	1
16	1123576	HYD. HOSE, 36" X 1/2", (OIL COOLER OPTION)	1
17	n/a	COUPLING, SEE ENGINE ASSEMBLY	1
18	n/a	BEARING, SEE ENGINE ASSEMBLY	1
19	n/a	PUMP MOUNT, SEE ENGINE ASSEMBLY	1
20	1190042	FILTER ASSEMBLY, INCLUDES CARTRIDGE	1
20	1190065	FILTER CARTRIDGE	1
21	1122878	TEE, 1/2" NPTF	1
22	1123210	90 ELBOW, #8 JICM X #8 ORBM	4
23	1123494	90 ELBOW, #8 JICM X 1/2" NPTM	1
24	1124364	90 ELBOW, #12 ORBM X 1" HOSE BARB	1
25	1190048	90 ELBOW, 1" NPTM X 1" HOSE BARB	1
26	1122898	ADAPTOR, 1/2" NPTM X 3/4" NPTM	1
27	1124407	ADAPTOR, 1/2" NPTM X 3/4" JICM	1
28	1123518	UNION, #8 ORBM X #8 ORBM	1
29	1190053	GEAR CLAMP	2
30	1190041	TANK STRAINER	1
31	1190099	BULKHEAD FITTING, #8 JICM X 1/2" NPTM	2
32	1122894	UNION, 3/4" NPTM (2)	1
NS	1127456	COUPLER, FEMALE 1/2" NPT, DRIPLESS	1
NS	1127457	COUPLER, MALE 1/2" NPTM, DRIPLESS	1

LIFT CYLINDER

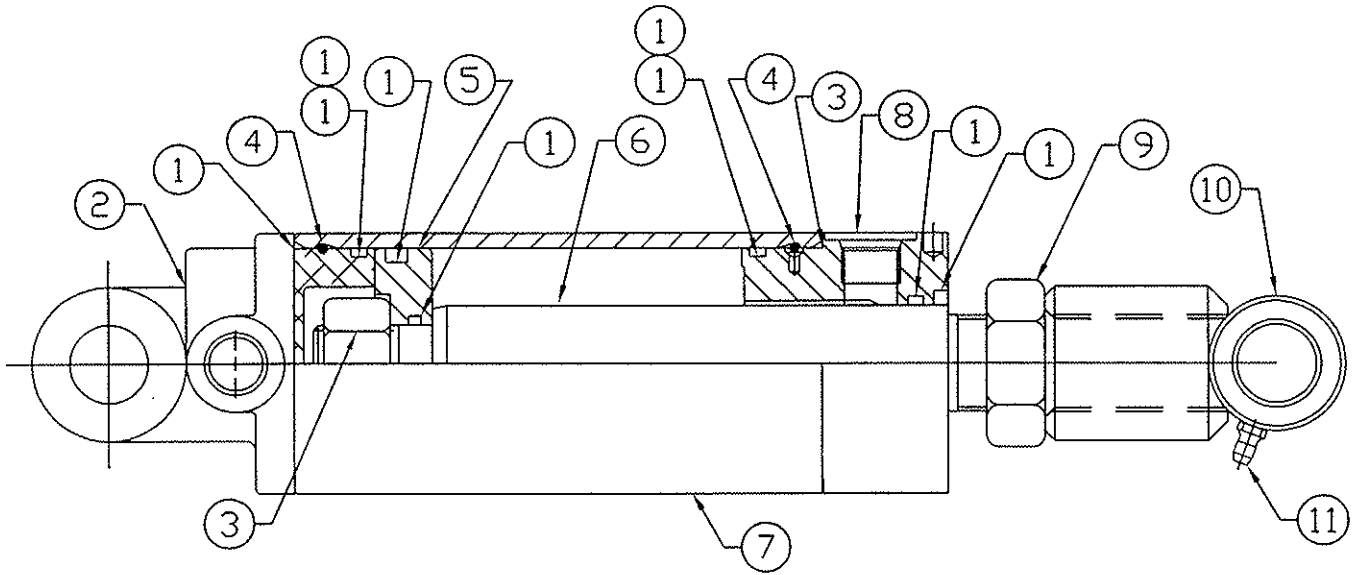

TILT CYLINDER

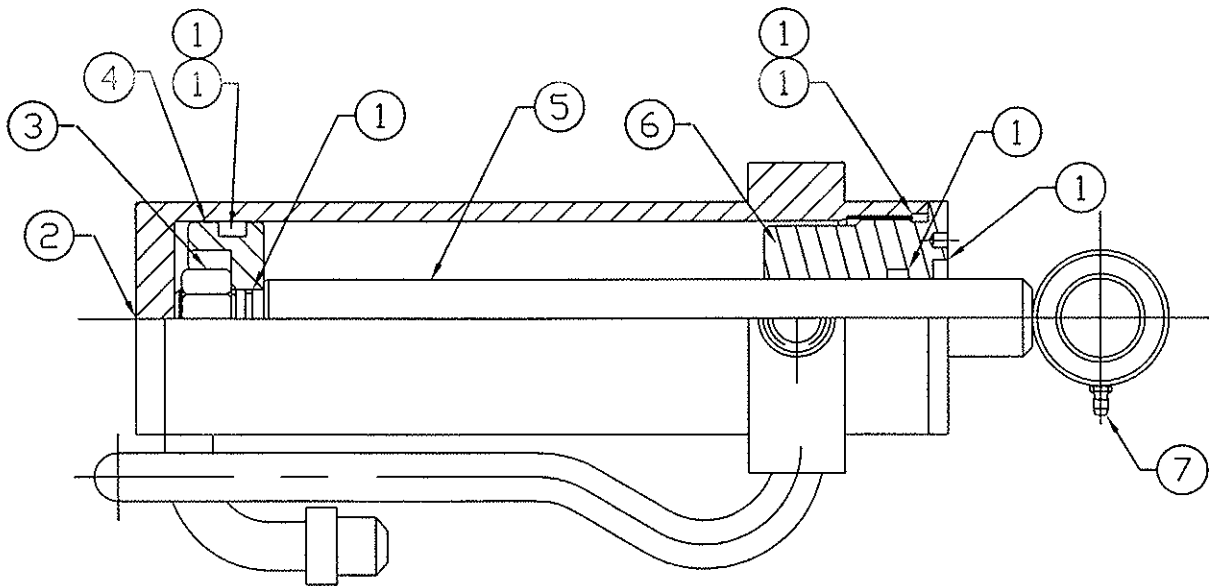

PARTS LIST - LIFT CYLINDER

Item	P/N	Description	Qty.
1	1125130	LIFT CYLINDER SEAL KIT	1
2	1125131	BUTT CLEVIS	1
3	1125132	LOCKNUT	1
4	1125133	RETAINING WIRE	2
5	1125134	PISTON	1
6	1125135	SHAFT	1
7	1125136	BARREL	1
8	1125137	CYLINDER HEAD	1
9	1125138	JAM NUT	1
10	1125139	CROSS TUBE	1
11	1122759	GREASE ZERK	1

PARTS LIST - TILT CYLINDER

Item	P/N	Description	Qty.
1	1128406	TILT CYLINDER SEAL KIT	1
2	1125115	BARREL	1
3	1125114	LOCKNUT	1
4	1125113	PISTON	1
5	1125112	SHAFT	1
6	1125111	GLAND	1
7	1122759	GREASE ZERK	1

23hp KAWASAKI ENGINE (FH680V)

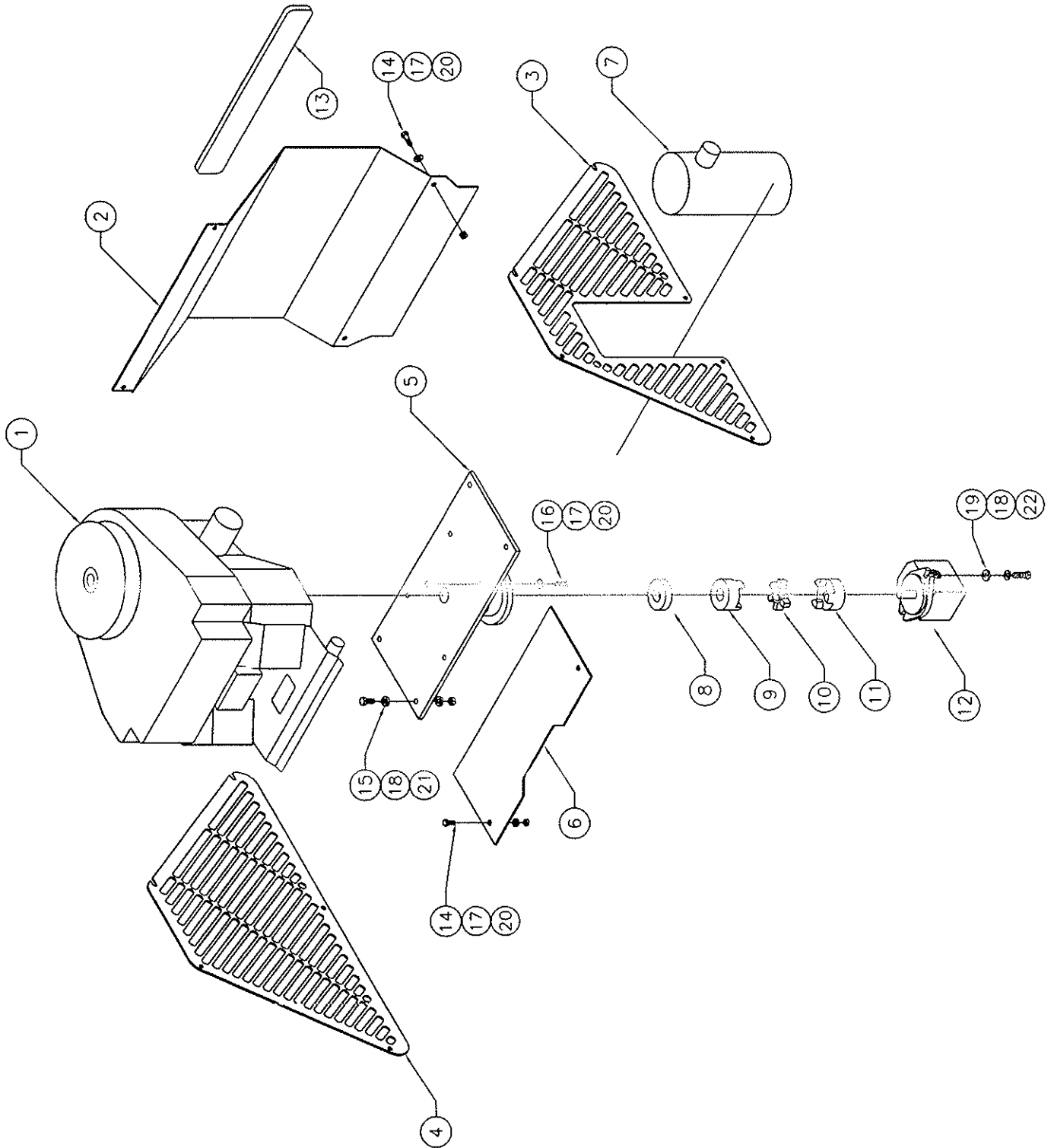

PARTS LIST - 23hp KAWASAKI ENGINE (FH680V)

Item	P/N	Description	Qty.
1	1190109	FH-680V 23HP AIR COOLED ENGINE	1
2	1235089	FH-680V INSTRUMENT PANEL	1
3	1235053	905 LEFT SIDE COVER	1
4	1235039	905 RIGHT SIDE COVER	1
5	1235026	FH-680V PUMP/MOTOR MOUNT	1
6	1235049	FH-680V MUFFLER SHIELD	1
7	1235512	FH-680V MUFFLER	1
8	1128347	BEARING, PPP-R16-2RS	1
9	1117083	COUPLING HALF, 1" KEYED	1
10	1117076	SPYDER	1
11	1117180	COUPLING HALF, 5/8" KEYED	1
12	1179325	HYDRAULIC PUMP	1
13	1190100	OPERATOR PAD	1
14	1101950	GR. 5 UNC HEX BOLT, 5/16" X 1"	5
15	1102002	GR. 5 UNC HEX BOLT, 3/8" X 1 1/2"	4
16	1101953	GR. 5 UNC HEX BOLT, 5/16" X 1 3/4"	4
17	1102608	FLATWASHER, 5/16"	9
18	1102609	FLATWASHER, 3/8"	10
19	1101998	GR. 5 UNC HEX BOLT, 3/8" X 1 1/4"	2
20	1102521	GR. 5 UNC LOCK NUT, 5/16"	8
21	1102526	GR. 5 UNC LOCK NUT, 3/8"	4
22	1102590	LOCKWASHER, 3/8"	2
NS	1190013	THROTTLE CABLE	1
NS	1190012	CHOKE CABLE	1
NS	1234533	TACH/HOURMETER	1
NS	1190014	IGNITION SWITCH	1

HYDRAULIC OIL COOLER ASSEMBLY (OPTIONAL)

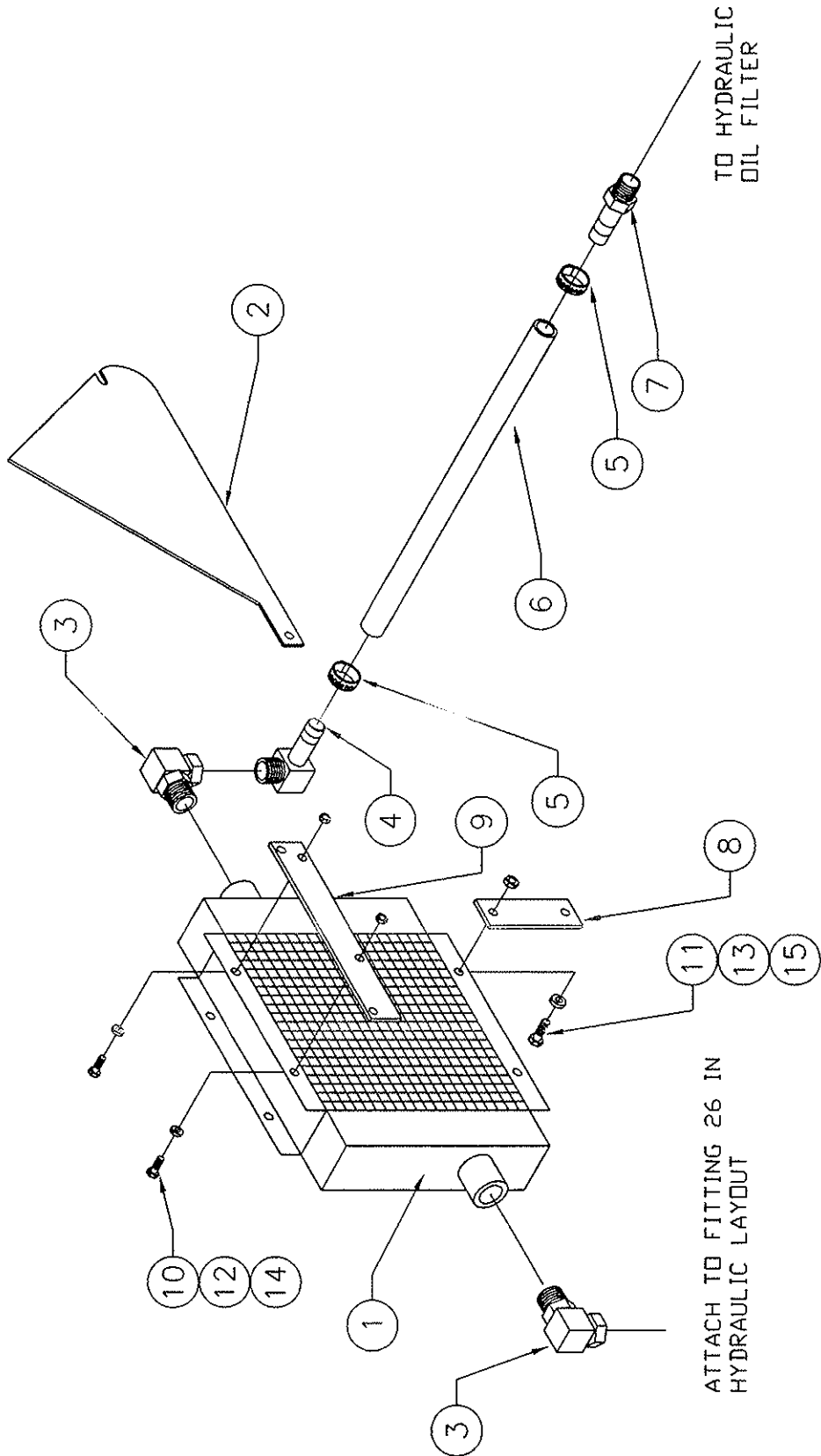

PARTS LIST - HYDRAULIC OIL COOLER ASSEMBLY

Item	P/N	Description	Qty.
1	1127513	OIL COOLER	1
2	1234595	OIL COOLER COVER PLATE	1
3	1122941	90 DEGREE ELBOW, #12 ORBM SW X 3/4" NPTF SW	2
4	1190043	90 DEGREE ELBOW, 3/4" NPTM X 3/4" HOSE BARB	1
5	1123290	GEAR CLAMP	2
6	1235513	SUCTION LINE, 3/4" X 24" LONG	1
7	1190044	ADAPTOR, 3/4" HOSE BARB X 3/4" NPTM	1
8	1234593	UPPER OIL COOLER BRACKET	1
9	1234594	LOWER OIL COOLER BRACKET	1
10	1101923	GR. 5 UNC HEX BOLT, 1/4" X 3/4"	2
11	1101949	GR. 5 UNC HEX BOLT, 5/16" X 3/4"	1
12	1102607	FLATWASHER, 1/4"	2
13	1102608	FLATWASHER, 5/16"	1
14	1102527	GR. 5 UNC LOCKNUT, 1/4"	2
15	1102521	GR. 5 UNC LOCKNUT, 5/16"	1

